

PRODUCT DATASHEET



RECOMMENDED FOR USE IN:

Carriageways carrying continuous heavy traffic in areas subjected to high surface water run off.

Featuring a double triangular grating design for durability, the Waterway range of D400 gratings provides efficient water clearing performance. In its larger sizes the Waterway range is particularly suited to applications such as catchpits, carriageway verges or surface water catchment areas.



DURABILITY

Includes the Load Transfer System (LTS) for optimum installation and product durability



WATER CLEARING EFFICIENCY

An efficient water clearing capacity aids the effective removal of surface water



ACCREDITATION

Third party certified by BSI and kite marked to the requirements of BS EN 124. Compliant to the requirements of Highways England advice note HA104/09



SAVE TIME & COST

Most sizes are available with the Install Plus frame levelling and installation system as standard



PERFORMANCE

Double triangular grating utilising 3 points of suspension to ensure it is non rock and silent in use



Saint-Gobain PAM UK

Tel: 0115 930 5000

www.saint-gobain-pam.co.uk

Email: sales.uk.pam@saint-gobain.com

WATERWAY D400 DOUBLE TRIANGULAR GRATING RANGE	ISSUE NO: SGPUK011	DATE: 03.2018
---	--------------------	---------------

Manufactured in the UK to the highest Quality, Environmental and Health and Safety standards.

WATERWAY TRIANGULAR NON-ROCK DUCTILE IRON GRATING AND FRAME

SAP CODE	SAP CODE WITH INSTALL PLUS+	BS EN124 CLASS	CLEAR OPENING A x B (mm)	OVER BASE C x D (mm)	DEPTH E (mm)	WATERWAY AREA (cm ²)	HA102 GRATING REF.	MASS OF GRATE (kg*)	TOTAL MASS (kg)	PALLET QTY	PREVIOUS REF.
WATERWAY 1200											
185972	255499	D400	435 x 435	587 x 525	100	1200	Q	25	43.2	20	BZ32 1
WATERWAY 2000											
185976	256073	D400	600 x 600	800 x 800	100	2000	N/A	57	88.5	10	BZ48
185978**	-	D400	600 x 600	720 x 800	100	2000	P	57	87.2	10	BZ50
240126**	-	D400	600 x 600	705 x 820	150	2000	P	57	95.8	10	BZ51
185979	-	D400	600 Dia	800 x 800	100	2000	N/A	57	93.1	10	BZ52
185980	256074	D400	600 x 600	820 x 780	150	2000	N/A	57	93.8	10	BZ54

WATERWAY 1200

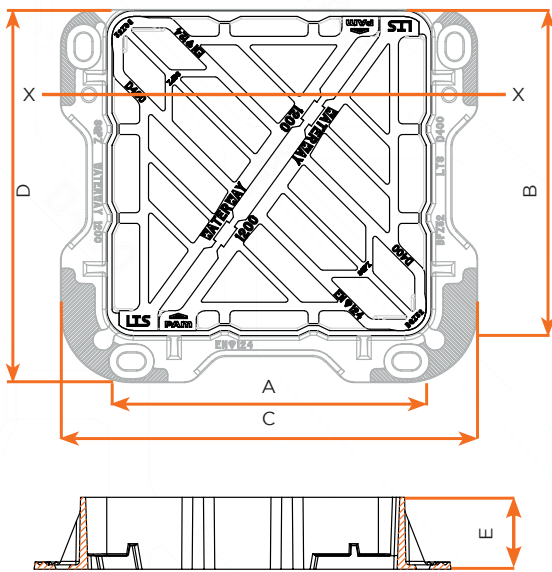

WATERWAY 2000

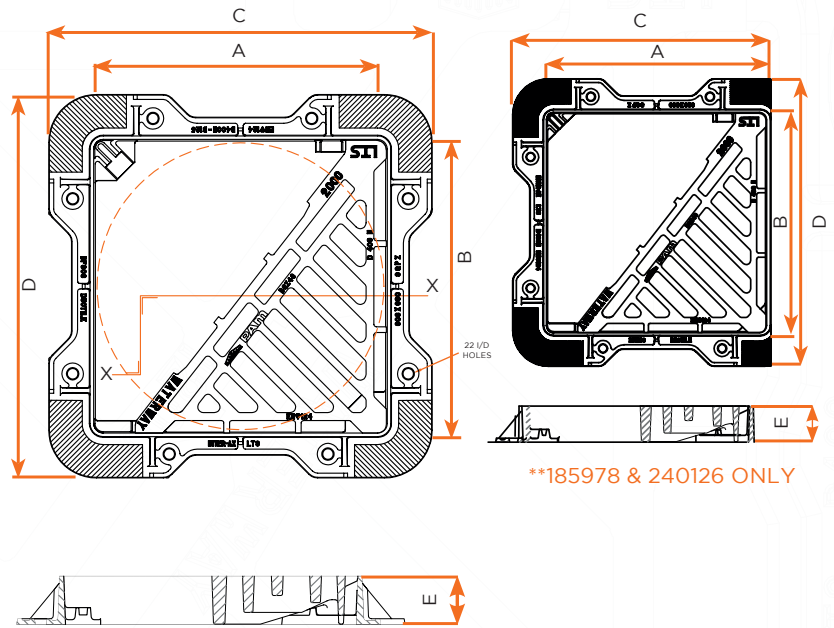

- + For Install Plus details see Install Plus information sheet
 - * Mass of 2 half gratings loosely coupled together
 - ** Three flanged frame
- Produced at Holwell Works, UK

The information on this sketch is, to the best of our knowledge correct at the time of printing. However Saint-Gobain are constantly looking at ways of improving their products and services therefore reserve the right to change without prior notice, any of the data shown. Any orders placed will be subject to our Standard Conditions of Sale, available on request.
 COPYRIGHT AND DESIGN RIGHT
 This drawing is the exclusive property of Saint-Gobain PAM UK and is confidential and must not be reproduced or disclosed for any third party without written consent. It must be used only for the purpose for which it has been issued and is returnable on request.

PRODUCT DATASHEET

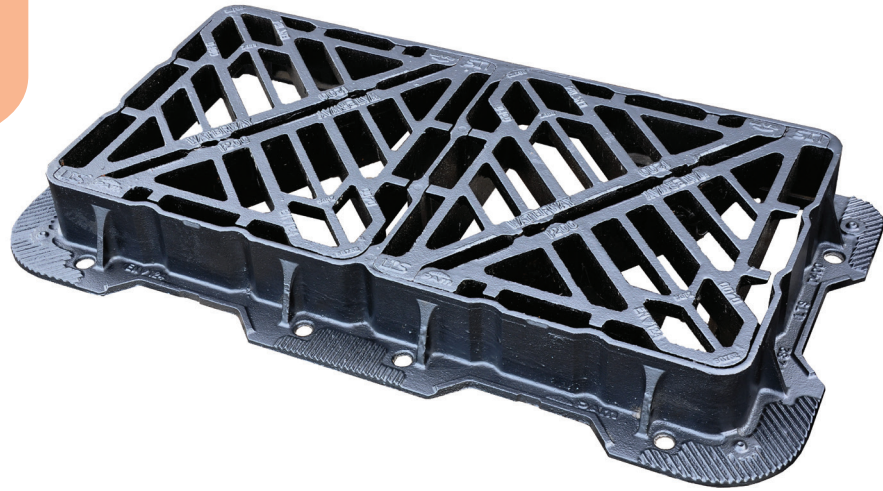

WATERWAY DOUBLE TRIANGULAR NON-ROCK DUCTILE IRON GRATING AND FRAME

SAP CODE	SAP CODE WITH INSTALL PLUS+	BS EN124 CLASS	CLEAR OPENING A x B (mm)	OVER BASE C x D (mm)	DEPTH E (mm)	WATERWAY AREA (cm ²)	HA102 GRATING REF.	MASS OF GRATE (kg*)	TOTAL MASS (kg)	PALLET QTY	PREVIOUS REF.
WATERWAY 2400											
211234	-	D400	425(x2) x 415	1036 x 525	100	2400	P	25	82	5	BZ82 1

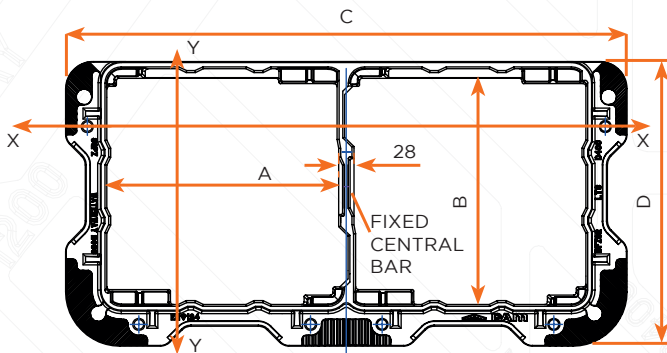
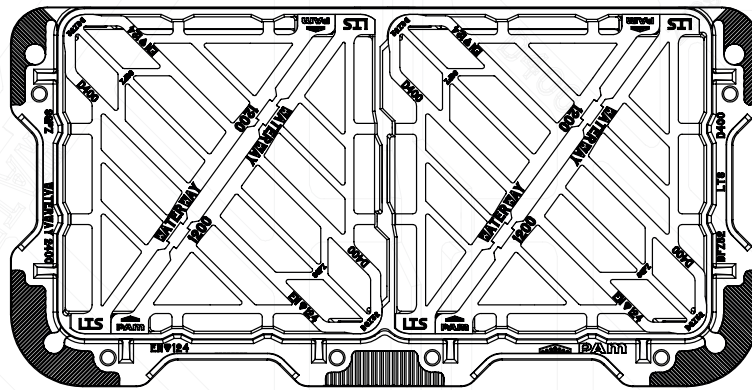

* Mass of 2 half gratings loosely coupled together
Produced at Holwell Works, UK

The information on this sketch is, to the best of our knowledge correct at the time of printing. However Saint-Gobain are constantly looking at ways of improving their products and services therefore reserve the right to change without prior notice, any of the data shown. Any orders placed will be subject to our Standard Conditions of Sale, available on request.

COPYRIGHT AND DESIGN RIGHT

This drawing is the exclusive property of Saint-Gobain PAM UK and is confidential and must not be reproduced or disclosed for any third party without written consent. It must be used only for the purpose for which it has been issued and is returnable on request.